

Advanced Licence Course Review Questions

1. Describe how voltage is measured.

2. Describe how current is measured?

Get the
exam
Formula
Sheet

3. Complete the table below.

Voltage (E)	Current (I)	Resistance (R)
12 V	2 A	
120 V		6 MΩ
	500 mA	20 Ω
60 V		1 KΩ
90 V	3.3 A	
24 V		6 MΩ
6 V	1000 A	
	3 mA	3 KΩ

4. If doubling the voltage across a resistor doubles the current through the resistor, then

- the resistor value decreased.
- the resistor value did not change.
- the resistor value increased.
- It is impossible to calculate.

5. If the voltage is increased five times across a fixed value of resistance, what does the current do?

- The current increases by a factor of five.
- The current decreases by a factor of five.
- Current stays the same.
- It is impossible to calculate
- Not enough information

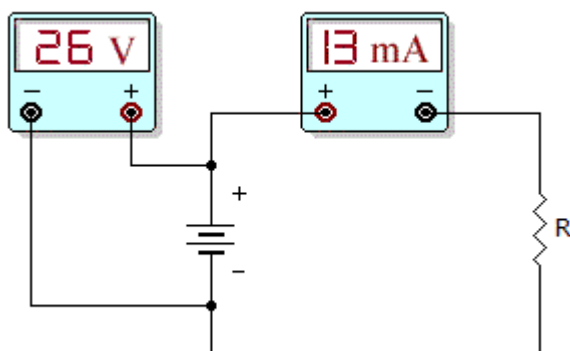

6. What is the resistor value in the given circuit?

IMPORTANT: Observe the difference in measuring voltage and current. Voltage is measured across the terminals, but current is measured in the circuit.

A. 200 Ohms

- B. 1k Ohms
- C. 2k Ohms
- D. 4k Ohms

7. If the voltage doubles across a fixed resistance

- A. The current is halved
- B. The resistance doubles
- C. The current is unchanged
- D. The current doubles

6. Ohm's law describes the mathematical relationship between

- A. ohms, kilohms, and megohms
- B. resistor size and resistor value
- C. resistance, voltage, and current
- D. none of the above

7. If current through a fixed resistance is halved

- A. the resistance is halved
- B. the voltage is halved
- C. the voltage doubles
- D. The current cannot change

8. If the voltage in the circuit to the right was cut in half, what would the current equal?

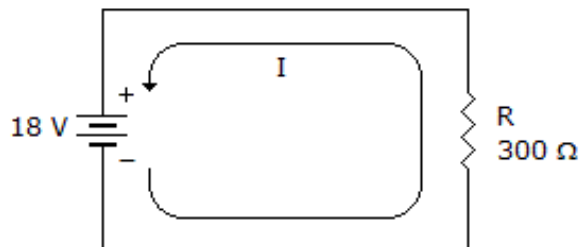

9 Describe the difference between conventional current flow and electron flow.

10. Complete the tables below.

Voltage (E)	Current (I)	Resistance (R)	Power (W)
12 V	0.75 A		
	0.4 mA	110 Ω	
		10.75 Ω	60 W
12 kV		25 Ω	
2 V	75 mA		
	3 A	1 M Ω	

11. What happens to the power level When the voltage, across a fixed load, doubles?

- A. the power value increased by 2.
- B. the lights go out.
- C. the power value increased by 4.
- D. It is imposible to calculate.

12. You accidently replace a 15 W bulb With a 5 W bulb in your car. The voltage remains at 12V. What Was the current drain originally and after you replaced the bulb?

- A. The current increases by a factor of three.
- B. The current decreases by a factor of three.
- C. Current stays the same.
- D. The bulb Will destruct

13. What is the power level dissipated in R?

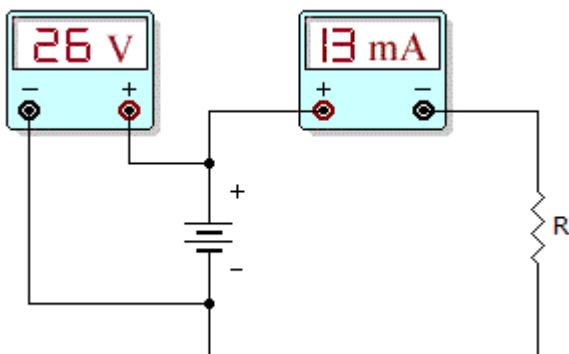

IMPORTANT: Observe the difference in measuring voltage and current. Voltage is measured across the terminals, but current is measured in the circuit.

- A. 338 W
- B. 10 W
- C. 0.338 W
- D. 3.38 W

1. The resistance in a circuit doubles What must happen to the voltage to keep the power dissipation constant?

15. If the energy of 120 joules is applied and this moves 6 coulombs, What is the required voltage?

- A. 2 V
- B. 20 V
- C. 0.2 V
- D. 200 V

16. If device 1 and 2 are 10 V batteries, What is the potential difference between A and B?

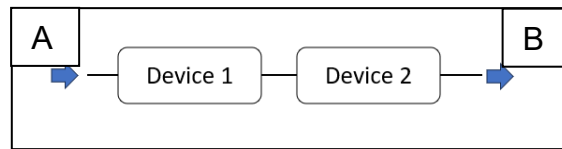

17. If device 1 and 2 are 10 V batteries, What is the potential difference between A and B?

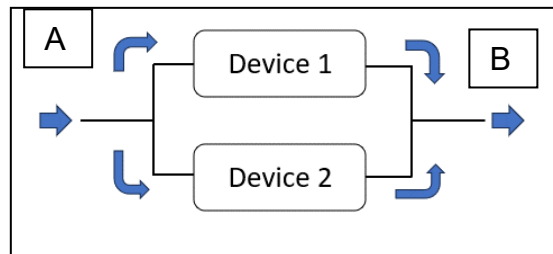

18. Complete the following table and indicate the correct formula and unit With the answer.

Unit	Unit	Answer
12 V	10 J	$V = J / Q$
5 A	20 Q	$A = Q / t$
5 kJ	20 seconds	$W = J / t$
100 V	6 Q	$V = J / Q$

19.

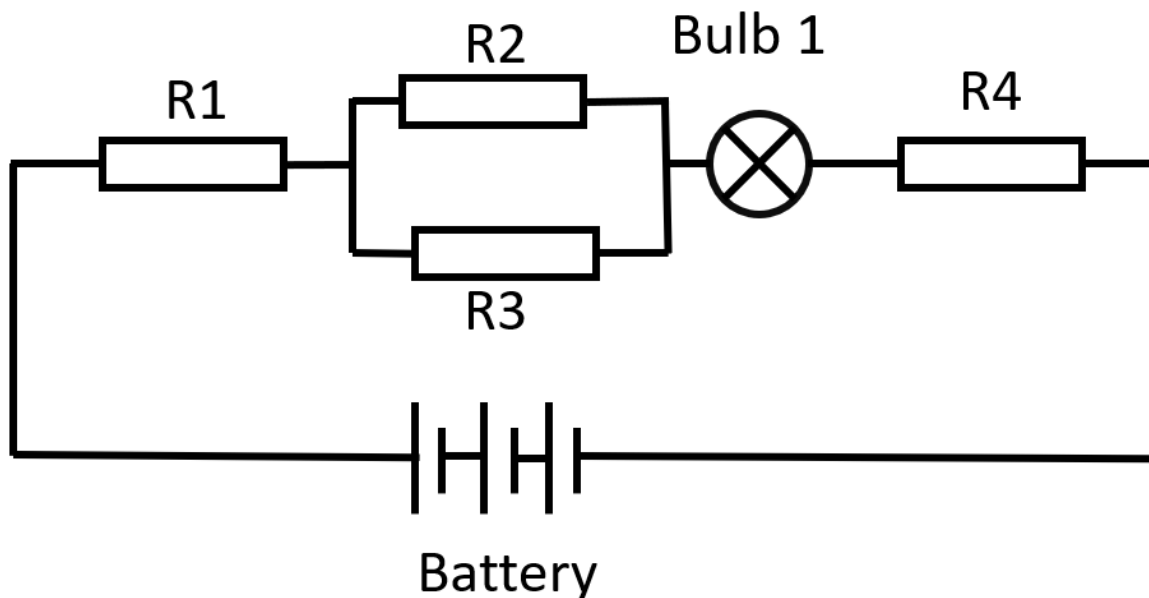

Complete the table assuming the following values.

Battery	Current	R1	R2	R3	Bulb	R4
90v	3A	6Ω	40Ω	40Ω		4Ω
12v		20 Ω	100 Ω	100 Ω	15 Ω	10 Ω
60v	60 mA	100 Ω			15 Ω	870 Ω

20. Prove Kirchhoff/s current law.

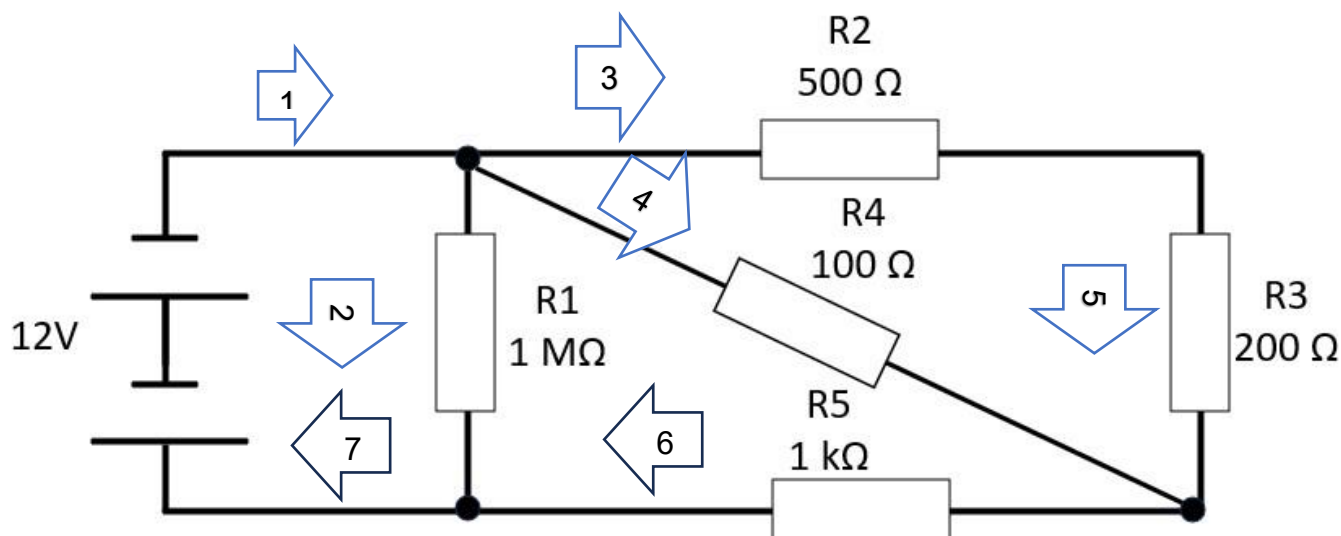

Hint: Redraw the equivalent circuit.

1	2	3	4	5	6	7

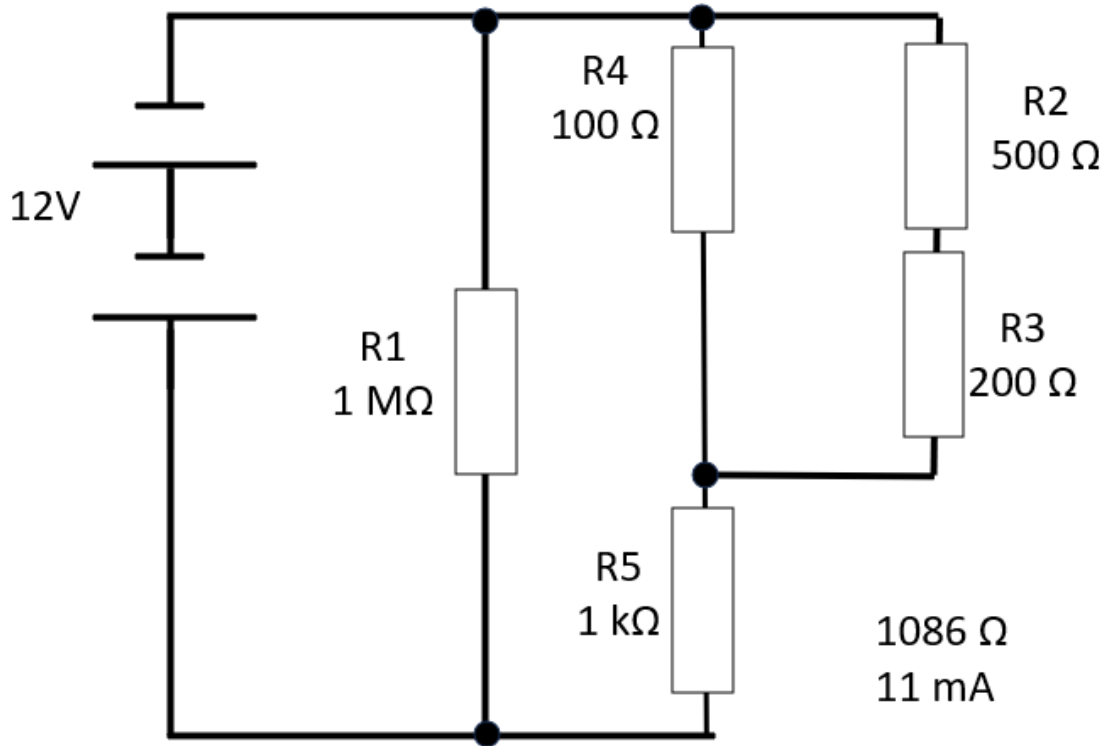

21. Complete the missing details,

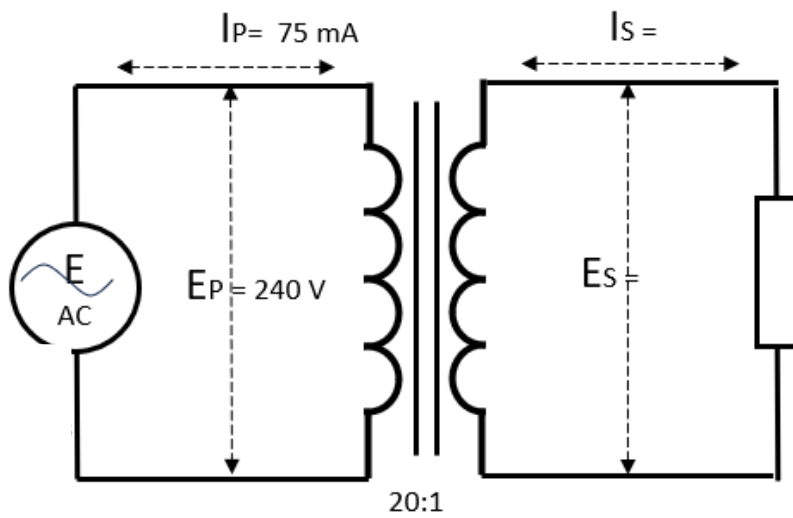

21A Complete the missing details..

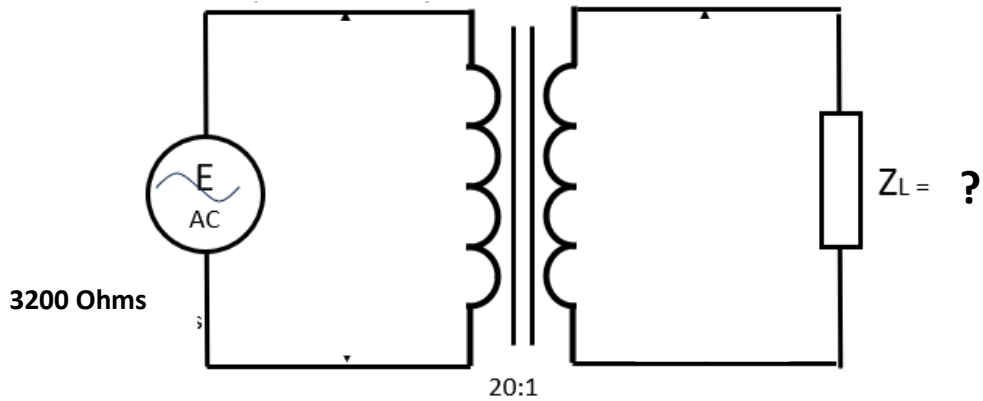

22. What is Peak Inverse Voltage (PIV) and how does it apply to the circuits above?
23. Name and describe the four modulation methods used by amateur radio operators.
24. What are the variables in designing a capacitor?

25. What is the total capacitance of these capacitors in series?

C1	C2	C3	C Total
3 mF	10 mF	2 mF	
6 pF	3 pF	1 pF	
6 nF	12 nF	1 nF	

26. What is the total capacitance of these capacitors in parallel?

C1	C2	C3	C Total
3 mF	10 mF	2 mF	
6 pF	3 pF	1 pF	
6 nF	12 nF	1 nF	

27. What is the total inductance of these inductors in parallel?

L1	L2	L3	L Total
16 mH	15 mH	21 mH	

16 pH	30 pH	0.1 pH	
60 nH	12 nH	100 nH	

28 What is the total inductance of these inductors in series?

L1	L2	L3	L Total
16 mH	15 mH	21 mH	
16 pH	30 pH	0.1 pH	
60 nH	12 nH	100 nH	

29 What is a filter and why are they used?

30 What is the reactance of a series tuned circuit at frequency?

- A. Low
- B. High
- C. Changes
- D. Does not resonate.

31 What is the reactance of a parallel tuned circuit at frequency?

- A. Low
- B. High
- C. Changes
- D. Does not resonate.

32 What is the configuration and purpose of the filters shown below?

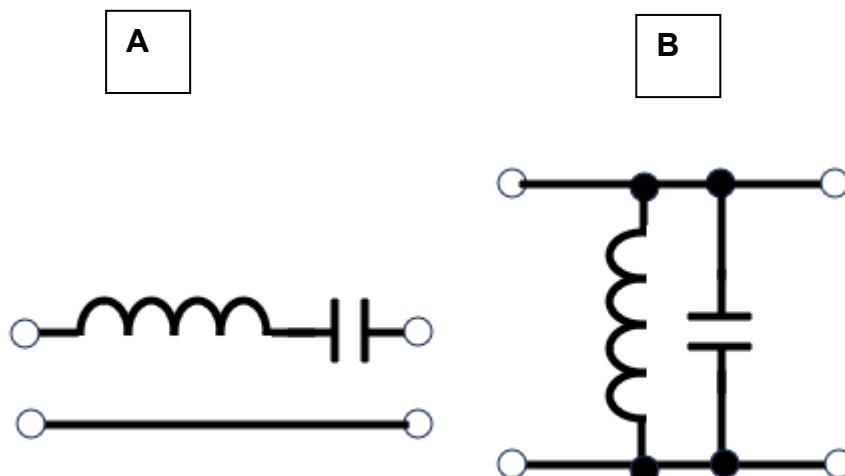

33 Describe the four basic filter configurations.

34. Describe where the cutoff point is for a filter.

35 Why is it necessary to be cautious when handling equipment with valves?

36 What is the gain of a valve if the change in plate voltage is 50 V and the change in grid voltage is 2 V?

37. Write the formula to calculate dBs in the following cases.

Voltage –

Power –

38. Complete the following decibel table. (Use the correct suffixes)

Input or Reference	Output	+ - Decibels
dB μ V	171 μ V	
12 V		- 6 dB
22 μ V	22 mV	
	100 V	10dB

39 Complete the following decibel table. (Use the correct suffixes)

Input or Reference	Output	+ - Decibels
0.25 W	6 W	
1.2 W		9.3 dB
dBW	12 W	
dBm	171 mW	

40 Draw the following diagrams for either NPN or PNP transistors. Include the characteristics of each configuration.

Common emitter

Common collector

Common base

Configuration	Input Impedance	Output impedance	Gain	Orientation
Common Emitter				
Common Base				
Common Collector				

- 41 Describe the following classes (A, B, AB and C) of amplifiers.
- 42 What is the forward bias of a diode?
- 43 Looking at the pin end of a three-pin plug, identify the terminals.

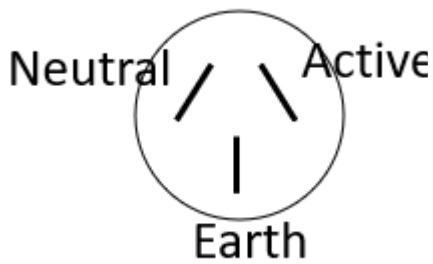

- 44 What is a power supply?
- 45 What is the difference in the output of a half wave rectifier compared to a full wave rectifier?
- 46 Draw the block diagram of a SMPS and name the parts.
- 47 Why is a RCD better than a fuse?
- 48 Complete the following table with regards to 230 V wiring.

Wire	Colour	Voltage to Ground
Active		
Neutral		
Earth		

- 49. What is the main oscillating component in a Pierce oscillator?
- 50. What was the first oscillator in use and why was it called a tickler oscillator?
- 51. What is a PLL?
- 52. Draw the block diagram of a PLL and name the parts.
- 53. Below are two oscillators. Name the oscillators.

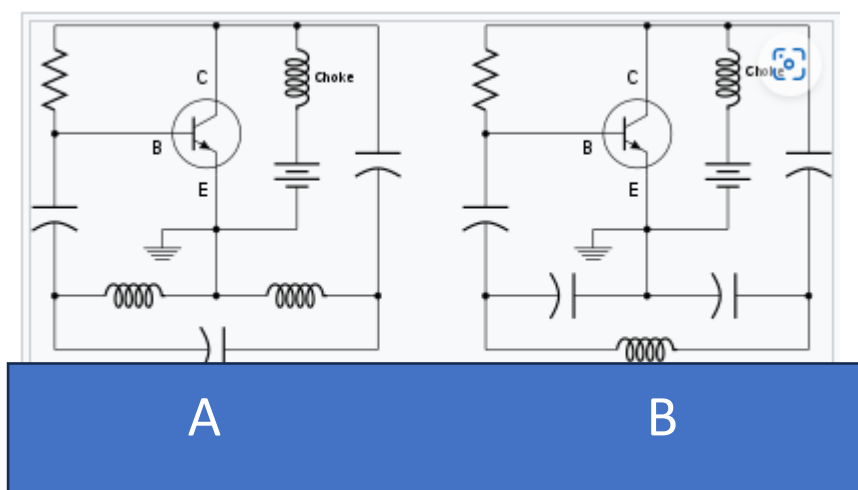

- 54. What is a BFO?
- 55. What is a VCO?
- 56. What are the three criteria for a receiver? Explain each criterion.

57. What is Thermal Noise?
 58. What is this circuit and where is it used?

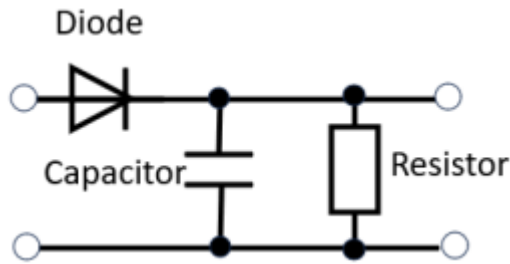

59. If the RF signal is f_c and the oscillator frequency is f_o , what are the two possibilities at the output of the mixer?
 60. What is an image frequency?
 61. What is the circuit below and where is it used?

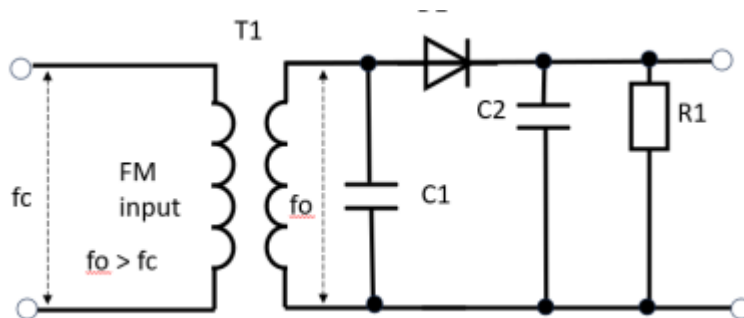

62. Below is the circuit of a Foster Seeley discriminator. What is it used for?

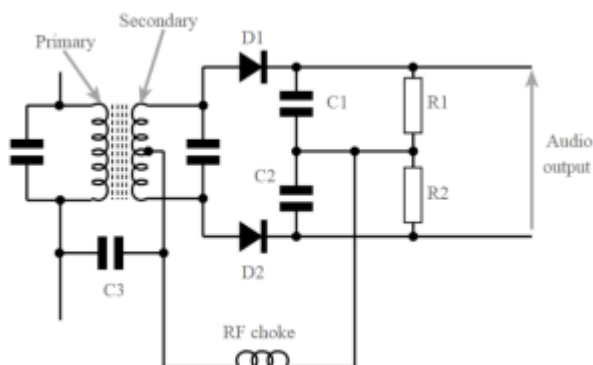

63. What is an IF frequency and why is it used?
 64. Name the seven types of demodulators?
 65. What is the signal to noise ratio of a 50 μ V signal and the noise level of 1 μ V?
 66. What is an S meter and what level is required for S9?
 67. What is de-emphasis?
 68. Draw a block diagram of an FM receiver.
 69. What is AGC and how does it work?
 70. Draw and label a block diagram of a simple AM transmitter.
 71. Draw an AM carrier wave modulated to 100%.
 72. What is a balanced modulator and why is it used?
 73. Where would an amateur operator find the emission modes for amateur use?
 74. What is the ALC?
 75. What duty cycle does RTTY transmission occupy?
 76. What bandwidth is occupied by a FM signal if a 2 kHz tone deviates the carrier by 100kHz?
 77. What are key clicks and chirps?

78. What are the five types of modulation used by amateur operators?
79. Describe how a dynamic speaker works.
80. What are ZS, ZO and ZL?
81. Name an unbalanced transmission line.
82. Name a balanced transmission line.
83. What is a waveguide?
84. Explain what is the SWR?
85. Measuring the signal on a transmission line, the maximum is 12 V and the minimum is 2 V. What is the SWR?
86. How do you test a transmission line to measure the continuity?
87. From the previous test, you got results of 500 Ω OC and 100 Ω . SC. What is the impedance of the line?
88. What is a balun?
89. Connecting a balanced line of 450 Ω to an unbalanced line of 50 Ω . What are the turns ratio for the balun?
90. What is the role of an antenna?
91. What are the three main groupings of antennas?
92. What is an isotropic antenna?
93. Name five types of antennas?
94. What are the three methods of polarising an antenna?
95. Why is the height of an antenna important for an amateur operator?
96. If an antenna under test resonates at a higher frequency than expected, is the antenna too short or too long?
97. The antenna in Q13 resonates at a frequency higher than expected, is capacitive reactance or the inductive reactance highest?
98. What is a capacitance hat on an antenna?
99. Polarisation of an antenna is related to voltage field or the magnetic field?
100. What is the angle of incidence for a radio wave?
101. Bending radio waves over geometric objects is called.....?
102. What is the critical frequency?
103. What is the maximum usable frequency?
104. Explain what is a noise floor?
105. What causes receiver noise?
106. What is a signal to noise ratio?
107. What ionospheric layer is responsible for most skywave propagation?
108. What is skip distance and skip zone?
109. Why is the input impedance of a multimeter important?
110. How do you measure current in a circuit?
111. Explain duty cycle in a waveform.
112. List two operator errors the user should consider when making a measurement.
113. What is a D to A?
114. What is an A to D?
115. What do the terms NRZ and RZ mean?
116. What are the two golden rules when using Op amps?
117. What is an open and closed loop amplifier?
118. What is Common Mode rejection?
119. What is EMI?
120. What is EMC?
121. Why does an Op amp have a + Vin and a -Vin?
122. What is the purpose of having an earth pin on the plug?
123. How does a fuse work?
124. What is the equipment that is replacing fuses on mains power and how do they work?
125. On which lead would the isolation switch be included and why?

- 126. What is a discriminator and a detector used for?
- 127. An inductor and capacitor each have 250 Ohms of reactance at 1kHz. If they are connected in series, what is their total reactance at 1kHz?
- 128. An inductor and capacitor each have 250 Ohms of reactance at 1kHz. If they are connected in parallel, what is their total reactance at 1kHz?
- 129. Does the power in the carrier of an FM modulated signal remain constant or change with the degree of modulation?

