

Lesson 7 – QUESTIONS

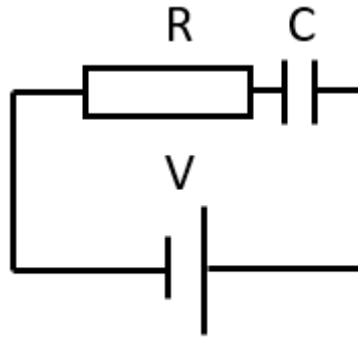

Series RC circuit

Q1 Complete the following table in relation to the diagram above.

R	C	Time Constant
10 MΩ	10 mF	
10 kΩ	2 F	
5 kΩ		3 second

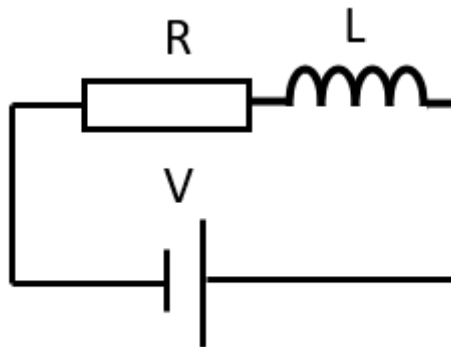

Series RL circuit

Q2 Complete the following table in relation to the diagram above.

R	L	Time Constant
10 MΩ	10 mH	
10 kΩ	2 H	
5 kΩ		3 second

Q3 What is resistance, reactance and impedance with regards to a tuned circuit? Explain their relationship.

Q4 What is the reactance of the following components at the allocated frequencies?

Capacitor	Frequency	Reactance
2 μF	1 MHz	
1 F	1 Hz	
1 F	100 MHz	
	28 MHz	10 Ω
3 pF		10 Ω

Q5 What is the reactance of the following components at the allocated frequencies?

Inductor	Frequency	Reactance
2 μH	1 MHz	
1 H	1 Hz	
1 H	100 MHz	
	28 MHz	10 Ω
3 H		10 Ω

Q6 At what frequency would the following tuned circuits be resonant?

Capacitor	Inductor	Frequency
3 pF	3 μH	
1 F	1 H	
1 μF	1 μH	
1 μF		14 MHz

Q7 What is the reactance of a series tuned circuit at frequency?

- A. Low
- B. High
- C. Changes
- D. Does not resonate.

Q8 What is the reactance of a parallel tuned circuit at frequency?

- A. Low
- B. High
- C. Changes
- D. Does not resonate.

Q9 What is the reactance of a parallel tuned circuit at any frequency outside of resonance?

- A. Low
- B. High
- C. Changes
- D. Does not resonate.

Q10 What is the reactance of a series tuned circuit at any frequency outside of resonance?

- A. Low
- B. High
- C. Changes

D. Does not resonate.

Q11. Draw a series LCR tuned circuit.

Q12 Draw a parallel LCR tuned circuit.

Q13 What is the Q of a tuned circuit?

Q14 Complete the following table for a series tuned circuit.

Reactance	Resistance	Q
10 Ω	1 Ω	
10 Ω	100 Ω	
10 Ω		10

Q15 Complete the following table for a parallel tuned circuit.

Reactance	Resistance	Q
10 Ω	1 Ω	
10 Ω	100 Ω	
10 Ω		10

Q16 Complete the following table for the bandwidth of tuned circuits.

Q	Resonant Frequency	BW
10	20 MHz	
35	20 MHz	
	20 MHz	10 kHz

Q17 What is a filter and why are they used?

Q18 Describe the four basic filter configurations.

Q19 Draw a choke and describe what it is used for?

Q20 What type of filter is a choke?

Q21 Describe where the cut-off point is for a filter.

Q22 What is a “T” and “ π ” configuration filter?

Q23 What is the characteristic of the filters shown below?

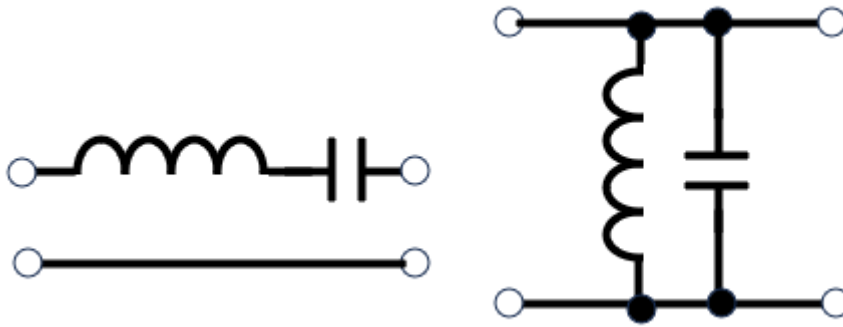

Q24 Draw the equivalent circuit for a piezo crystal and explain the parts.

Q25 Do a google search and read about the Butterworth and Chebyshev filters.

Q26 Design a LC band stop filter for 6.5 MHz centre frequency.

Q27 Design a LC band pass filter for 10.7 MHz centre frequency.

Q28 Design a low pass filter to 400 MHz.

Q29 Design a high pass filter from 500 MHz.

There are many filter design and simulation programs on the internet. Test and prove your design with these.

