



Chapter 3-1

Transmitters

ACMA Foundation Syllabus 3.4, 4.1 - 4.9

Contents

Transmitter	2
Oscillator	3
Transmission Types	3
Modulation.....	3
Deviation and Power	4
Transmitter Tuning	5
Frequencies	5
Transmitter Matching.....	5
Audio Frequency Gain Control (AGC).....	5
Amplitude Modulation (AM).....	5

Transmitter

A **transmitter** is an electronic device used to generate and transmit electromagnetic waves carrying information. Information can be music, voice, data or simple morse code.

Signals from the transmitter are sent to the antenna which radiates the energy as radio waves.

The beating heart of a transmitter is the **oscillator**.

An oscillator is an electronic device that produces signals in the form of a sine wave at a specific frequency.

The simplest transmitter would be an oscillator set at the carrier frequency and the oscillator turned the oscillator on and off. Very impractical and weak transmitter but covers the basics.

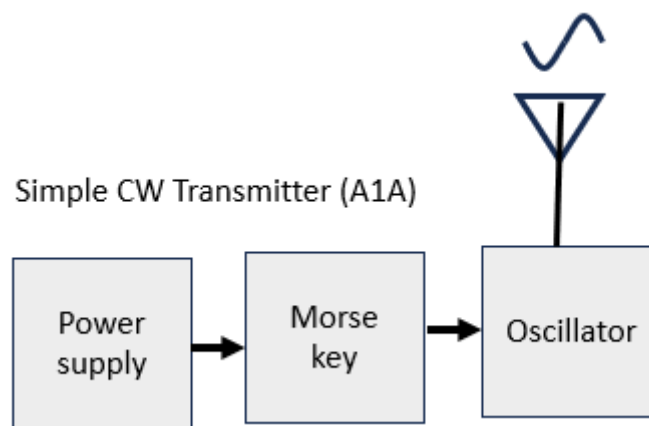

This transmitter could only produce a carrier wave or carrier signal. The only information passed would be morse code.

What is needed, is a better way to embed information on to the carrier wave. This process is called **modulation**.

Modulation is the process of embedding the information signal into the carrier.

By including modulation into the transmitter, we could build a simple audio transmitter is shown below.

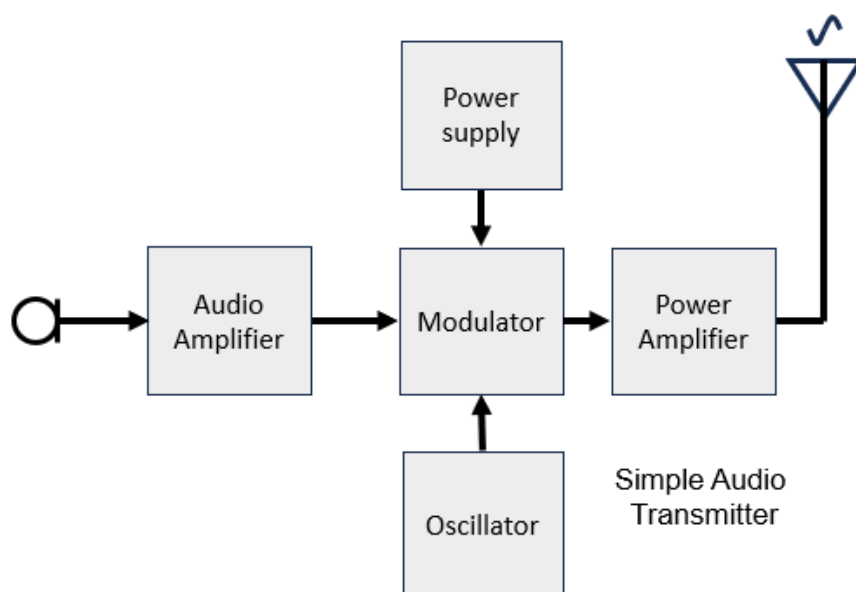

The information to be transmitted is amplified in the audio amplifier then modulated with an oscillator at the carrier frequency. This modulated signal is amplified and sent the antenna.

Oscillator

An oscillator circuit generates the radio frequency signal which is usually a sine wave of constant amplitude. This is called the *carrier wave* because it produces the radio waves which "carry" the information. In modern transmitters, the oscillator is precisely controlled by the vibrations of a quartz crystal. The frequency of the carrier wave is considered the frequency of the transmitter.

Varying the frequency of the oscillator allows the transmitter to cover a broad band of frequencies.

Transmission Types

There are two basic types of transmission.

- **Telegraphy** - This is the transmission of information by **Morse code**. (Dots and Dashes)

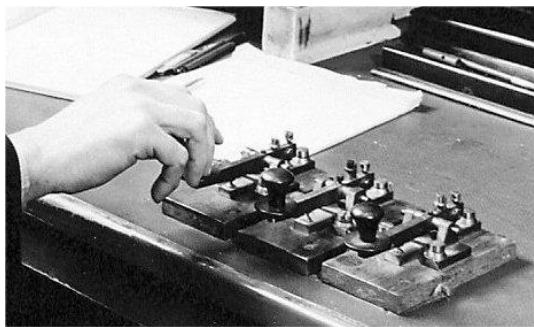



- **Telephony** – This is the transmission of information by **voice**.



Modulation

Modulation is the process of superimposing an information audio signal onto the carrier signal. If we want a HF transmitter at 28 MHz there are several ways to superimpose the and the audio range of 300 hertz to 3.4 Kilohertz onto the carrier signal.

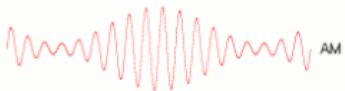
In the amateur radio arena, there are four primary methods of modulating an analogue signal with an intelligent signal. The primary modulation methods used by radio amateurs are AM , FM, CW and SSB.

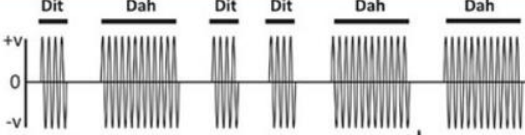
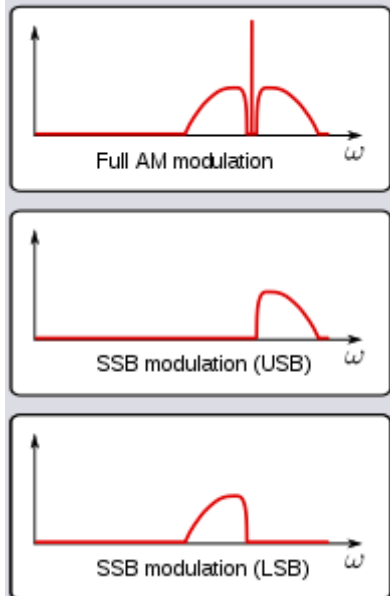
Amplitude modulation (AM)	AM is a modulation technique where the amplitude of the carrier is varied in proportion to that of the message signal.	
Frequency modulation (FM)	FM is a modulation technique where the frequency of the carrier wave is varied by the message signal.	
Continuous Wave (CW)	The term continuous wave refers to a method of radio transmission in which a sinusoidal carrier wave is switched on and off as in Morse code.	
Single-Sideband modulation (SSB)	SSB is a refinement of amplitude modulation, SSB uses transmitter Single-sideband modulation avoids this bandwidth increase, and the power wasted on a carrier, at the cost of increased device complexity and more difficult tuning at the receiver.	 <p style="text-align: center;">Wikipedia Single-sideband modulation - Wikipedia</p>

Deviation and Power

Deviation is the frequency change in the carrier of an FM signal. Power transmitted does not change with operator voice.

Space the signal occupies is called bandwidth.

The Foundation licence operator can only transmit a power level of no more than 10 W peak.

Voice peaks when using SSB should not exceed 10 W. This is referred to as peak envelope power (PEP) and often referred by the letters P_x . P_y is the average or mean power.

When transmitting FM, the carrier power does not change with the voice like SSB. Instead, the carrier signal is said to deviate with the modulation. Again, the carrier power cannot exceed 10 W.

Excessive modulation of any carrier can cause the carrier signal to be distorted. This distortion can cause interference to other operators.

Awareness of the microphone gain control will help keep the signal power within limits.

Occupied bandwidth is the frequency spectrum (space) on that frequency you occupy when you transmit.

Transmitter Tuning

The ability of the transmitter to remain within the frequency bands allocated to amateur radio can be lost if the transmitter is miss tuned or over driven. This can cause the signal to be distorted and result in interference to other radio users.

Frequencies

Operators have a duty to keep their transmissions within the allocated frequencies. The ACMA can take action against an operator not complying with the frequency boundaries and clarity of transmission.

Transmitter Matching

The output impedance of the transmitter must match the input impedance of the transmission lines and the antenna. Any mismatch can cause reflections in the transmitter and damage the output stage. (See VSWR)

Audio Frequency Gain Control (AGC)

A transmitter can be over driven if the audio signal over modulates the carrier wave. The AGC is a circuit that controls the audio input level to be modulated.

Amplitude Modulation (AM)

AM changes the amplitude of the carrier signal in sync with the audio signal. In the diagram below, the carrier signal is blue. Over modulation of the carrier signal will distort the signal and can cause interference to other users.

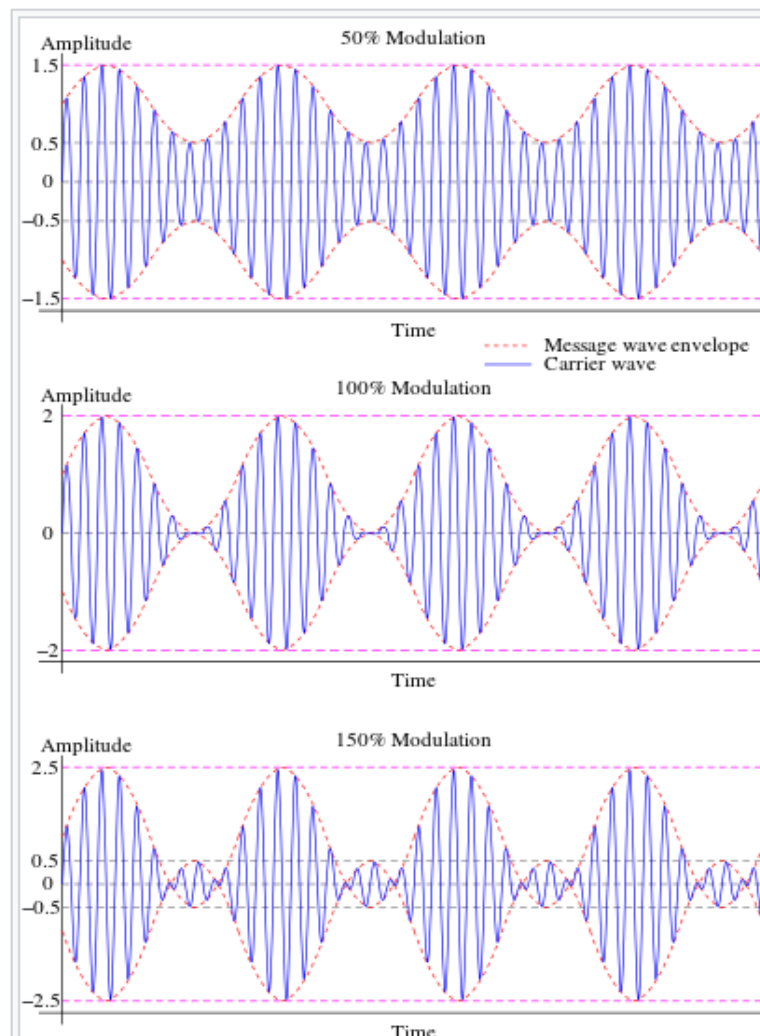

Go to Chapter 3-1 Questions.

Have fun and stay safe.