



Chapter 5-3

SWR

ACMA Foundation Syllabus 5.12, 5.14 – 5.16 and 8.1

Contents

Impedance Matching	2
Standing Wave Ratio (SWR)	3
Testing the SWR	3
Impact	4
Consequences	4
Limits	5
Percentages	5
Measuring SWR	6
Regular Checks	6
Actions	6
Antenna Tuning	7
Further Reading	7
Antenna Tuning Unit (ATU)	8
Role	8
Dummy Load	9

Impedance Matching

When connecting an antenna to a radio (transmitter or receiver) there are three components, and their associated connections, to be considered in the match.

1. Transmitter (and receiver)
2. Transmission Line
3. Antenna

To achieve maximum power transfer from the transmitter to the airwaves, the output impedance of the transmitter must match the input impedance of the transmission line, and the output of the transmission line must match the input impedance of the antenna.

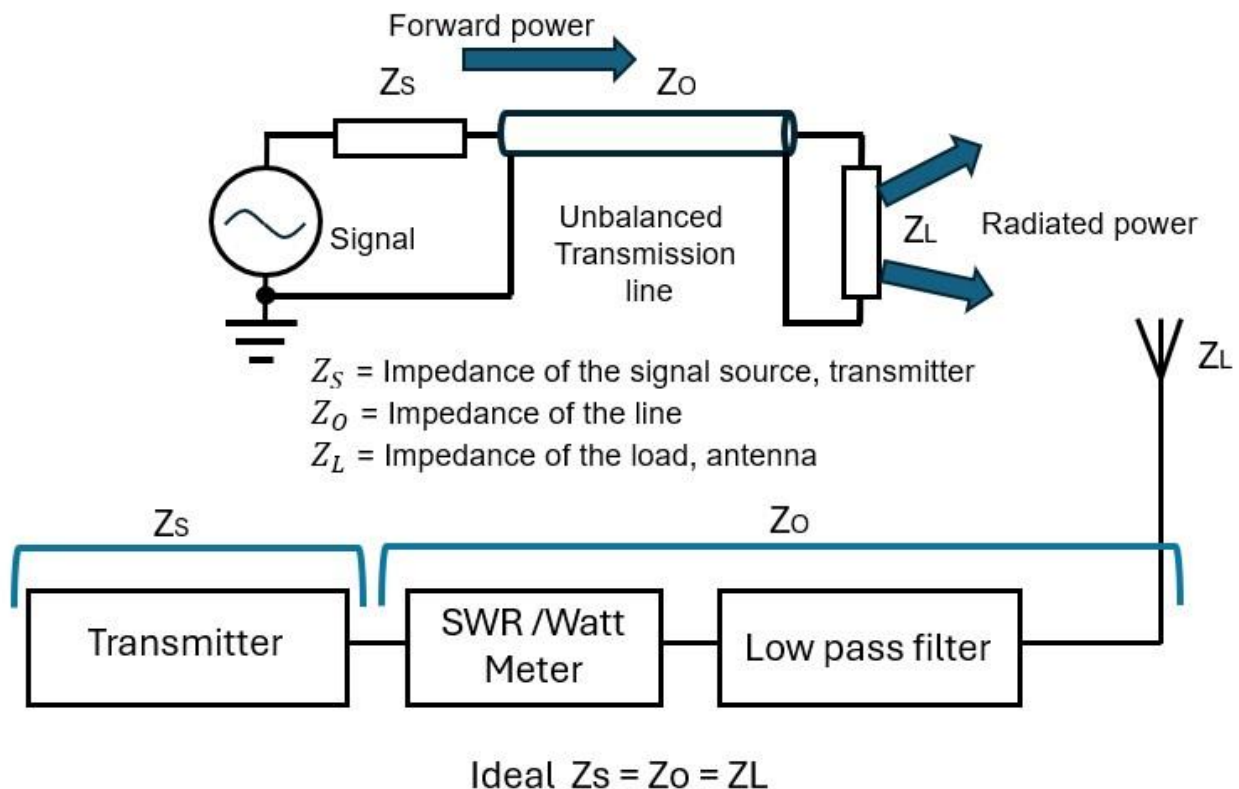

If $Z_S = Z_O = Z_L$, a matched condition exists. Attach an oscilloscope to the antenna emitting a simple carrier wave, the signal on the oscilloscope would be a perfect carrier sine wave. All the power is transmitted to the antenna.

Any mismatches, and a portion of the signal from the transmitter is reflected to the transmitter. Just like an echo in a bare room. If this reflection is a wave, this is not good. A ripple is ok. The comparison of this reflected wave is called the SWR.

An antenna is a complex load with resistance and reactance. For this article, I am only addressing antennas as Z_L for simplicity.

Standing Wave Ratio (SWR)

The definition for SWR I found is shown below.

“SWR is a measure of impedance matching of loads to the characteristic impedance of a transmission line. Impedance mismatches result in standing waves along the transmission line, and SWR is defined as the ratio of the partial standing wave's amplitude at an antinode (maximum) to the amplitude at a node (minimum) along the line.”

That is a mouthful. Simply, it means measure the high, measure the low, and compare.

SWR meters are passive instruments that measure forward and reflected voltage, and in addition to the SWR scale often include a power scale in Watts.

Testing the SWR

The most common and frequent test amateurs perform with equipment shown in Photo 1, is the Voltage Standing Wave Ratio (VSWR) measurement on their antennas. In many instances, the V is dropped, and the term becomes the SWR.

The test equipment measures the voltage of the signal from the transmitter to the antenna and compares this signal with the signal reflected from the antenna.

The SWR value is expressed as a ratio with figures such as 2:1, 5:1, etc. This is a numerical ratio and has no units. When there is a perfect impedance match between the transmitter and the load, the SWR will be 1:1. But when there is a complete mismatch with a short or open circuit, the SWR value is Infinity:1. (Infinity to 1)



Photo 1 - Various VSWR meters.

Impact

The reason a wave is not good is that as the reflected wave from any mismatch adds and subtracts to the forward wave, producing a standing wave. The forward and reflected waves are moving up and down along the transmission line. As the waves come into phase, the voltages add, and at that point are the maximum (antinode). As the waves go out of phase, the voltages subtract and are at the minimum (node).

Figure 3 gives an indication of how the waves moving in and out of phase can become very large. For example, a SWR of 1.2:1 means the peak voltage is 1.2 times the minimum voltage along that line.

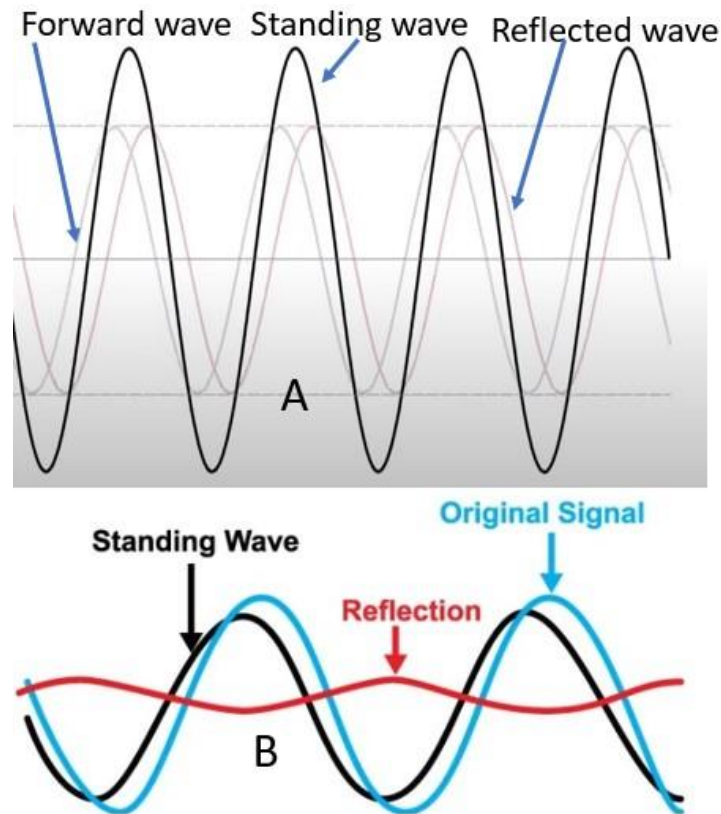

Figure 3 – Examples of a standing wave.

The wave in Figure 3A is an example of an open or short circuit mismatch. The forward and the reflected waves are at the same amplitude. Figure 3B is an example of a more moderate mismatch.

Consequences

Some negative side effects of a high SWR include:

- Transmitter power amplifiers can be damaged.
- PA Protection in modern transmitters reduces output power.
- High voltage and current levels can damage the transmission lines.
- Delays caused by reflections can cause distortion in the signal.
- Reduction in signal strength compared to perfectly match system.

Limits

- SWR 1.0-1.5 Ideal.
- SWR 1.5 - 1.9 There's room for improvement.
- SWR 2.0 - 2.4 Should not damage your radio with casual use.
- SWR 2.5 - 2.9 Performance decreased.
- SWR 3.0+ Could cause damage with degraded performance.

Percentages

The table below demonstrates the percentages of power and voltage reflected to the transmitter from a mismatched SWR.

VSWR	Voltage Reflected %	Power Reflected %
1.0 : 1	0	0
1.1 : 1	5	0.2
1.2 : 1	9	0.8
1.3 : 1	13	1.7
1.4 : 1	17	2.8
1.5 : 1	20	4
1.6 : 1	23	5.3
1.7 : 1	26	6.7
1.8 : 1	29	8.2
1.9 : 1	31	9.6
2.0 : 1	33	11
2.5 : 1	43	18.4
3.0 : 1	50	25
4.0 : 1	56	36
5.0 : 1	67	44.4
10.0 : 1	82	67

Measuring SWR

The SWR meter is placed in circuit after the transmitter and before the ATU. See figure below.

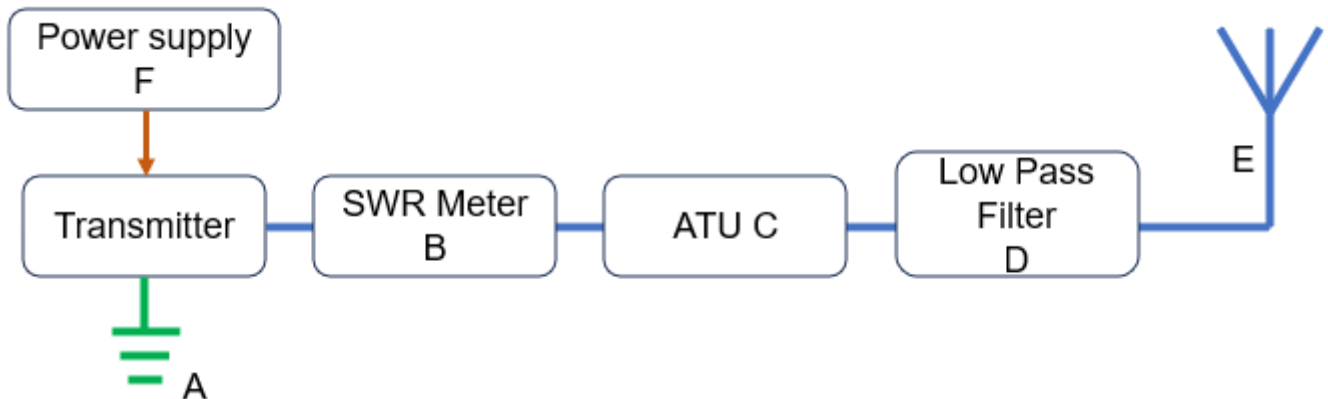

- Adjust the transmitter to the required frequency and switch to low power.
- Check your squelch or RF gain is not set too high.
- Listen on the frequency.
- If the frequency is clear, announce your call sign and say you are testing.
- Listen on the frequency.
- Transmit a steady signal with CW or FM.
- Calibrate the SWR meter in accordance with the SWR meter instructions.
- Switch the meter to SW test and retransmit.
- Read the SWR meter.

Regular Checks

Mismatches can occur with components of different impedances or a faulty connector. I had an active antenna in use for some time. After a holiday I checked the SWR, and the reading was very high. Water had penetrated the connector and caused corrosion. So, check your VSWR regularly. Taught me a lesson to always have my SWR meter permanently in the equation.

Actions

If you have a high SWR reading, immediately stop transmitting and find the source of the problem. The problem I had was water in the line connectors.

If you just built a new antenna and you have a high SWR, the antenna may need to be TUNED to bring the SWR into acceptable range for the frequency.

Antenna Tuning

When an antenna is not of the proper length, the source will see something other than the pure resistance, at the resonant point.

- If the SWR is better at higher frequencies, the antenna is too **short** and **capacitive** reactance is present. Lengthen the antenna.
- If the SWR is better at lower frequencies, the antenna is too **long**, and **inductive** reactance will be present. Shorten the antenna.

Further Reading

The examples used often refer to the transmitter. SWR effects receivers equally in terms of transmission line degradation and consequential receiver performance. Information about related factors such as increased losses in coaxial cable due to high SWR, and how such losses can be mitigated with Open Wire Feeder, is available in respected antenna publications by John D Kraus W8JK, William I Orr W6SAI, ARRL, RSGB, et al.

Antenna Tuning Unit (ATU)

An antenna tuner, also known as antenna matching unit, impedance matching unit, matchbox, matching network, transmatch, antenna match, antenna tuning unit (ATU), antenna tuner, or feedline tuner. The ATU is a passive electronic device placed in between the radio transmitter and the transmission line. The ATU does not change the transmission line or the antenna impedance. The ATU only provides the transmitter with the correct matching impedance. The photo below shows the inside of an ATU.



Role

The antenna tuner's role is twofold.

- Match the output impedance of the transmitter to the input impedance of the antenna tuner. This ensures maximum power transfer from the transmitter to the antenna tuner.
- Match the output impedance of the antenna tuner to the input impedance of the antenna system.

What the antenna tuner cannot do.

- Tune the antenna.
- Alter the antenna systems feed point impedance ($Z_o + Z_L$) or SWR.
- Alter the antenna's impedance (Z_L)
- Improve the efficiency of the antenna.
- Increase the power to the antenna beyond the transmitter power output. (The tuner is not an amplifier.)



Dummy Load

A good dummy load is an essential piece of equipment in the shack. The dummy load not only dissipates the signal energy when tuning the transmitter, it is a perfect impedance match of 50 ohms to substitute as a transmission or antenna load. Getting a high SWR and not sure where the mismatch is? Substitute the dummy load for the sections in the transmission line or antenna.



Go to Chapter 5-3 Questions.

Have fun and stay safe.